



# ROMETAL



Manual de Montagem  
Manual de Instalación

SISTEMA DESLIZANTE OCULTO PARA PORTAS DE PASSAGEM  
SISTEMA CORREDIZO OCULTO PARA PUERTAS DE PASO

## VOLARE



## Principais características do sistema/ Principales características del sistema



Portas de até 80 Kg  
Puertas hasta 80 Kg



Largura da porta: de 800 a 1220 mm  
Ancho de la puerta: de 800 - 1220 mm



Portas de madeira  
Puertas de madera



Antidescarrilamento  
Antidescarrilado



Sistema suspenso  
Sistema suspendido



Sistema de amortecimento  
Sistema de amortiguación

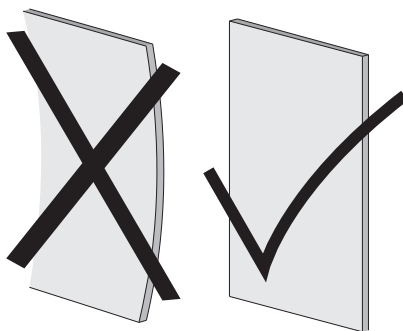

Verificar se o móvel está nivelado e as portas não estão empenadas.  
Compruebe si el mueble esta nivelado y si las puertas no eston pandeadas.

## Estrutura para fixação/ Estructura para fijación

Caso a instalação seja feita em parede de tijolo furado ou gesso, verificar se a estrutura foi preparada para sustentar a fixação do sistema e o peso da porta.

Si la instalación se realiza en la pared de ladrillos huecos o yeso, compruebe si el marco fue preparado para apoyar el sistema y el peso de la puerta.

**Componentes do kit para 1 porta/  
Componentes del kit para 1 puerta**

Itens na caixa/ Ítems en la caja		
Componentes		Qtd
	Trilho superior <i>Riel superior</i>	1
	Amortecedor <i>Amortiguador</i>	2
	Carro lateral <i>Carro lateral</i>	2
	Tampas de acabamento <i>Tapas de acabado</i>	1
	Carro inferior <i>Carro inferior</i>	2
	Trilho inferior <i>Riel inferior</i>	1
	Guia inferior <i>Guía inferior</i>	1
	Carro superior <i>Carro superior</i>	1
	Parafuso philips <i>Tornillo philips</i> ST 4,5 x 40	5
	Bucha <i>Buje</i>	5
	Parafuso philips <i>Tornillo philips</i> ST 4 x 16	25
	Parafuso fixo hexagonal <i>Tornillo hexagonal fijado</i> M4 x 6	4
	Chave allen <i>Llave allen</i> 2 mm	1
	Chave allen <i>Llave allen</i> 4 mm	1

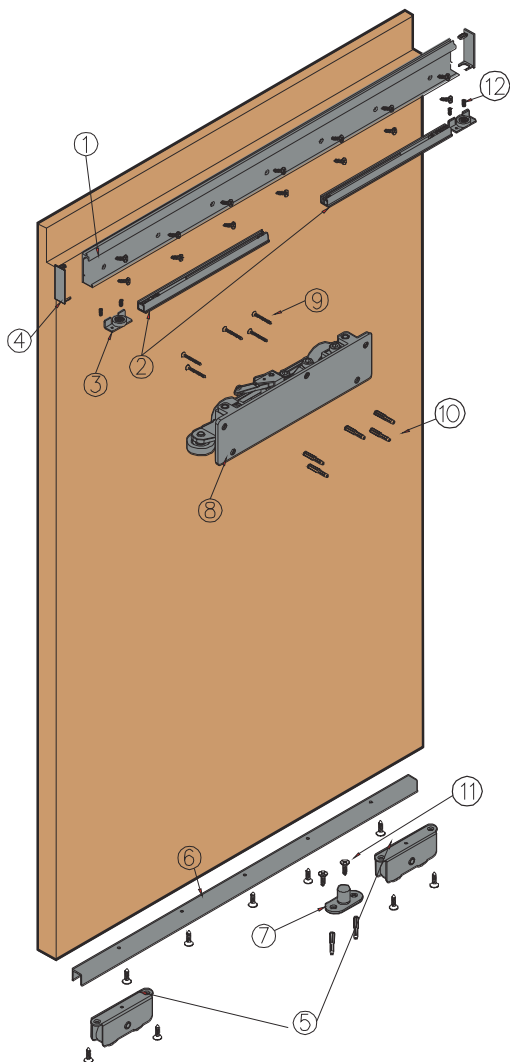

# Requisitos da largura da porta/ Requisitos de ancho de la puerta

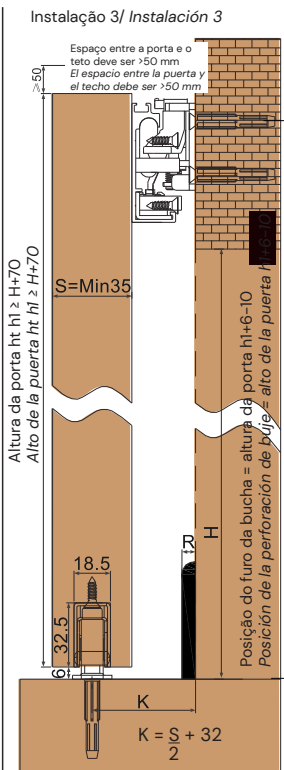
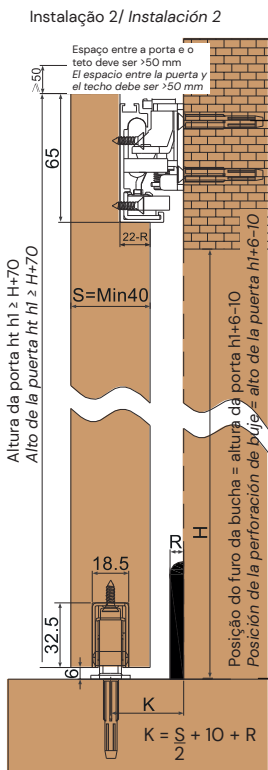
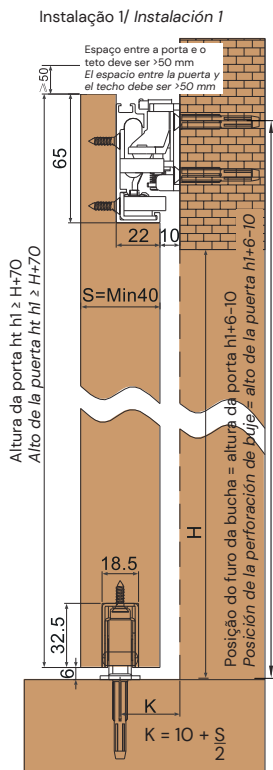

## Dimensões do trilho e modo de instalação 1/

### Dimensiones del riel y modo de instalación 1

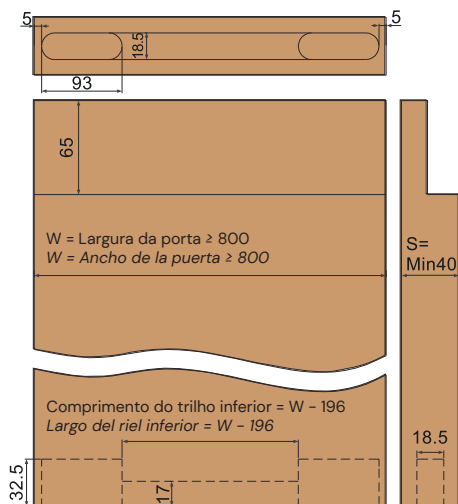

## Dimensões do trilho e modo de instalação 2/

### Dimensiones del riel y modo de instalación 2

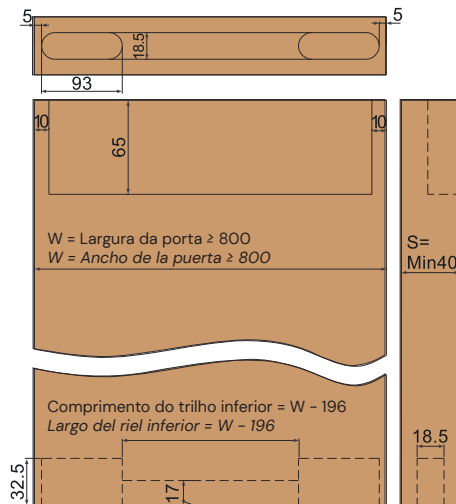

## Modo de instalação 1 para porta de madeira (porta completamente aberta)/ Modo de instalación 1 para puerta de madera (puerta abierta por completo)

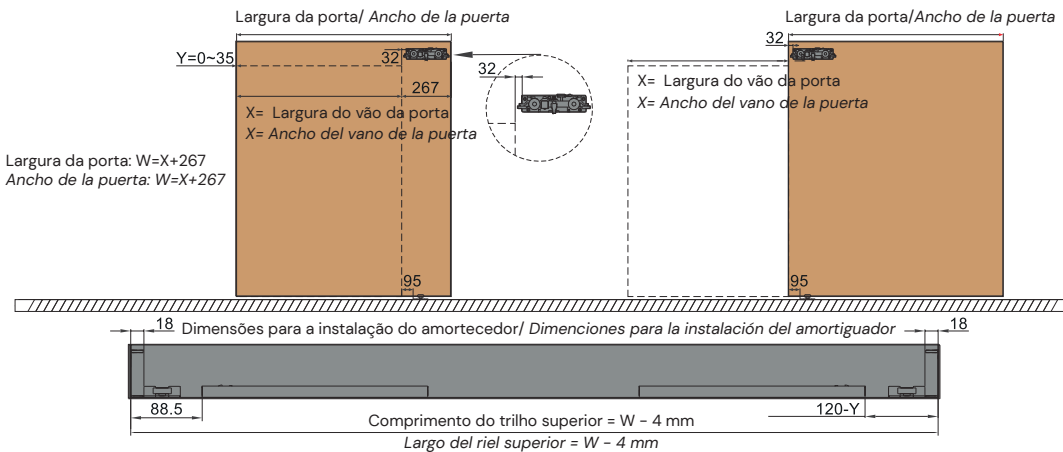

## Modo de instalação 2 para porta de madeira (porta parcialmente aberta)/ Modo de instalación 2 para puerta de madera (puerta abierta parcialmente)

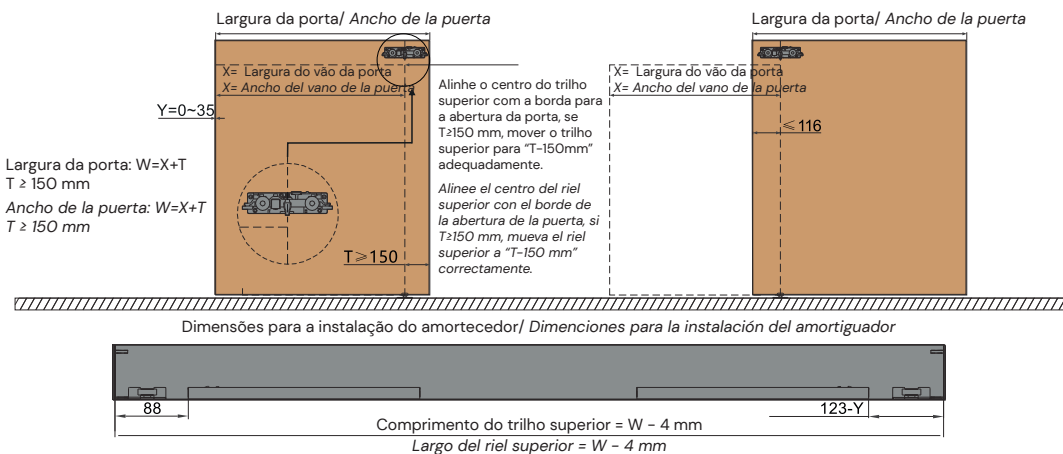

**1** Prenda o trilho superior.  
Fije el riel superior.

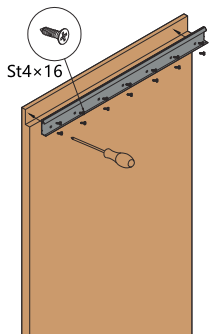

**2** Encaixe os amortecedores.  
Encaje los amortiguadores.

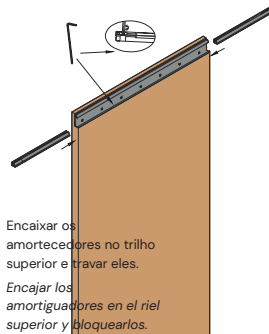

**3** Prenda o carro lateral.  
Fije el carro lateral.

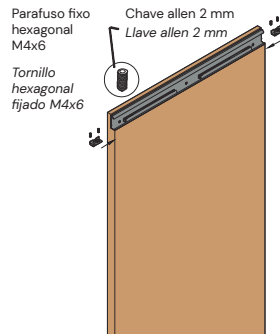

**4** Encaixe a tampa de acabamento nas extremidades do trilho superior.

Encaje la tapa de acabado en los extremos del riel superior.

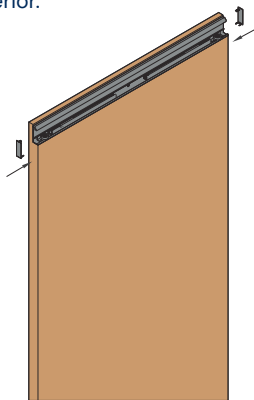

**5** Prenda o trilho inferior e ambos os carros inferiores.

Fije el riel inferior y los dos carros inferiores.

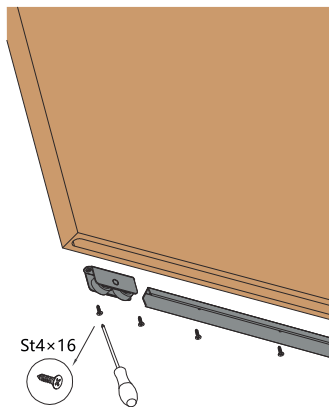

**6** Prenda o carro superior.

Fije el carro superior.

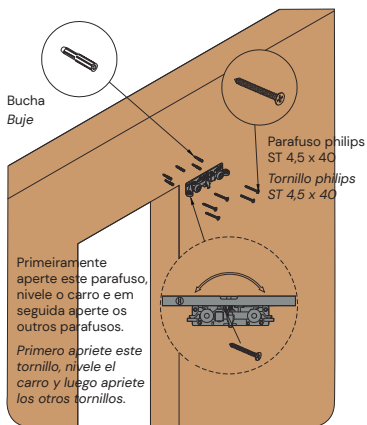

**7** Parafuse o guia inferior.

Atornille el guía inferior.

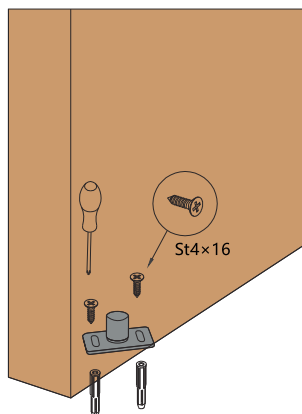

**8** Acione a trava de segurança.

Active el bloqueo de seguridad.

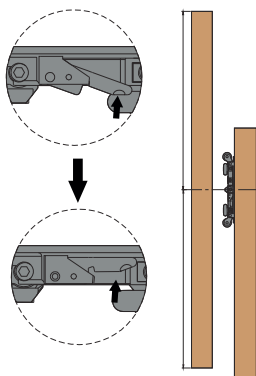

**9** Prenda a porta.

Fije la puerta.

Não pressione o guia inferior ao prender a porta.  
No presione la guía inferior cuando fija la puerta.

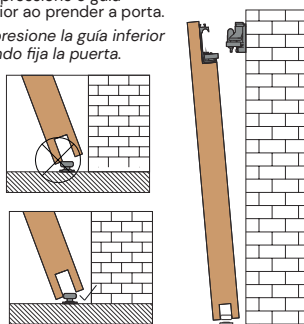

10

### Ajuste de altura. Ajuste de altura.

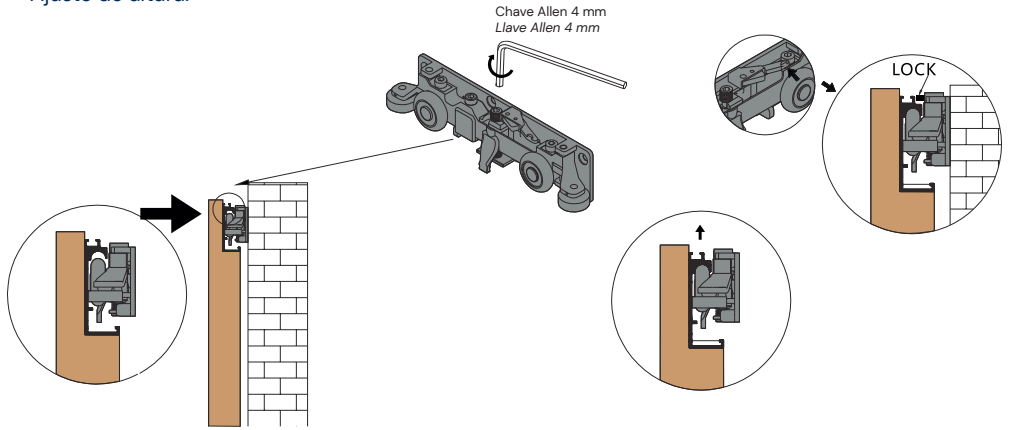

11

### Ajuste esquerdo e direito. Ajuste izquierdo y derecho.

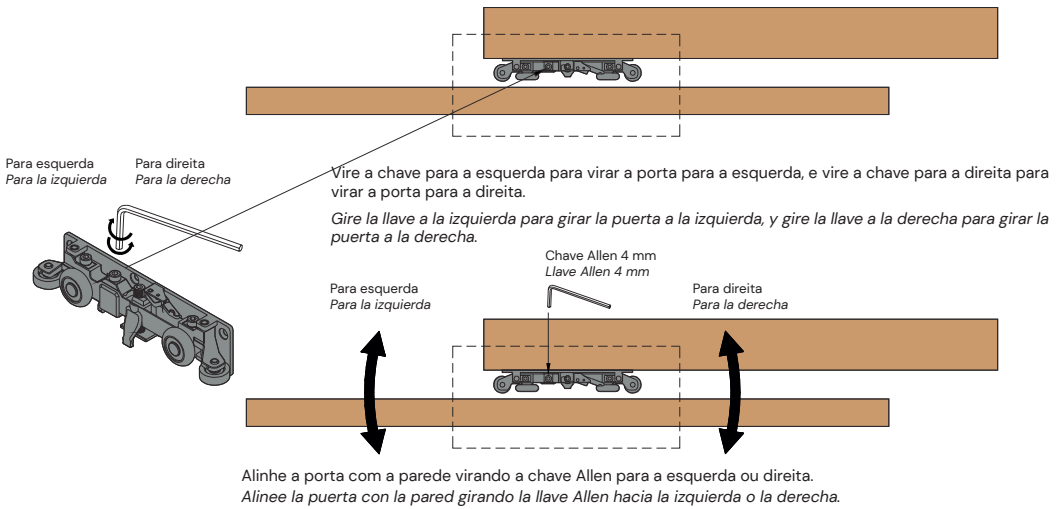

12

### Bloqueie a trava de segurança. Bloquear el bloqueo de seguridad.

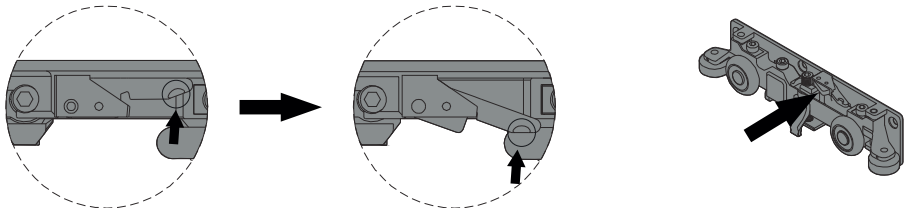



Cód.: 15763

Rev.: 11



[www.rometal.com.br](http://www.rometal.com.br)

**Unidade Sistemas**

Rodovia BR 470, km 174,5, nº 4075  
Bairro Universal | Veranópolis  
RS | Brasil | CEP 95330-000

**Unidade Alumínio**

Estrada Velha da Vacaria, nº 1339  
Bairro Sapopema | Veranópolis  
RS | Brasil | CEP 95330-000